

**ECOLO<sup>®</sup>**



ISO  
9001  
QUALITY  
ASSURANCE

# OUR ODOR CONTROL BUSINESS



**Wastewater**



**Solid Waste**



**Commercial**



**Industrial**

- Since 1973, we have been providing odor control technologies and turn key distribution models for use in Wastewater, Solid Waste, Industrial and Commercial markets.
- We now have more than 200 licensed distributors operating in over 40 countries.





# ECOLO CORPORATE OFFICES

## Manufacturing / Distribution



### ECOLO Toronto, Canada

- Corporate direction
- International distribution
- Chemical formulation
- Systems manufacturing
- Packaging and logistics
- Product development
- R&D and Lab



### ECOLO Houston, USA

- Southern US & central America distribution
- Systems manufacturing
- Service operations



### ECOLO Nanjing, China

- Asia Pacific distribution
- Systems manufacturing
- Biochemical R&D
- Service operations



### **AirSolution<sup>®</sup> Odor Neutralizers**

*Patented and proprietary solutions for commercial odor management such as **municipal waste transfer stations, compactor sites and commercial trash rooms** (e.g., restaurants, shopping malls, hotels and hospitals)*

### **BioStreme<sup>™</sup> Micronutrient Formula**

*A proprietary Micronutrient Formula designed to propagate indigenous bacteria for industrial applications including **landfills and wastewater treatment plants**.*

### **AirStreme<sup>™</sup> Systems**

*Automated misting equipment and applications for **odor control, pest control, environmental cooling and dust suppression**.*



Most sites with problematic odors require solutions that will permanently **neutralize** the odors, and not be confused with perfumes or **masking** agents

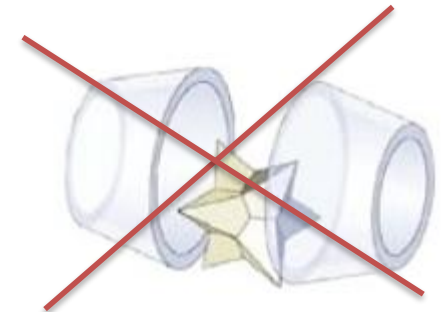

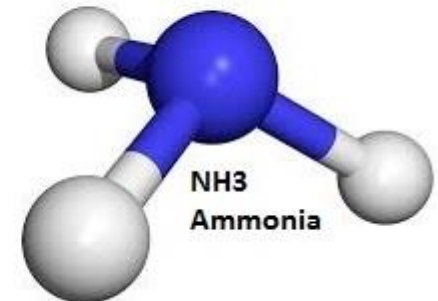
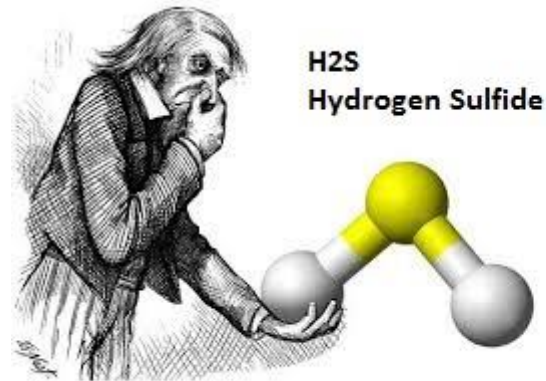
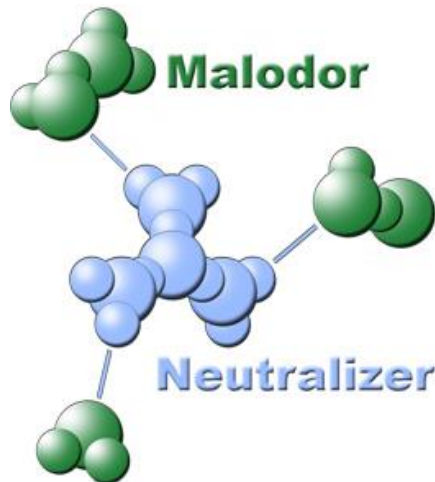

Masking unwanted odors



### ***Airborne Odor Control***

UNLIKE SIMPLE MASKING AGENTS, our Misting Odor Neutralizer contains powerful reactants made from essential oils, surfactants, and aromatics. Airborne droplets attract and neutralize odors through active chemical processes.

-  Airborne Misting Odor Neutralizer
-  Neutralized Odor
-  Odor

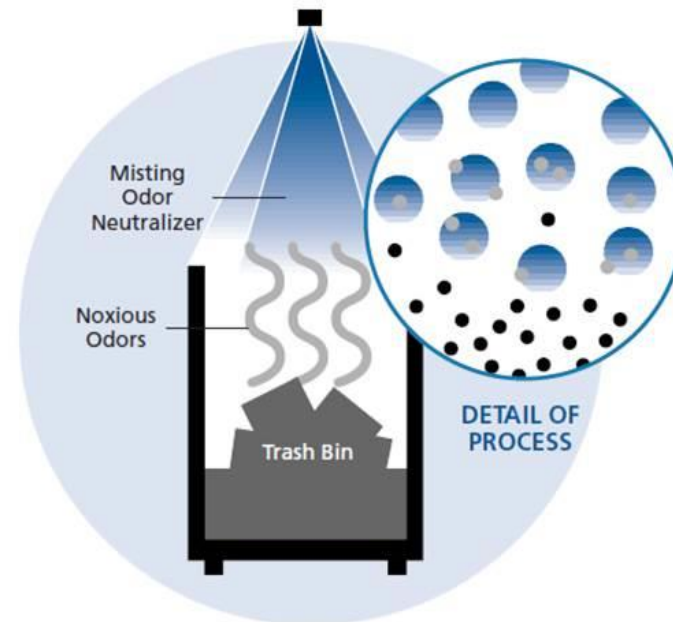

With its patented Two-Aldehyde essential oil technology, AirSolution uses several methods to remove odors. AirSolution has electrostatic attractive potential against odor molecules which increases their chances of collision. Collision lets them form a new, bigger molecule with different characteristics. Unlike scenting or masking agents, AirSolution's **patented** technology **permanently neutralizes the odor** by reacting with it.



Ecolo's **AirSolution™** are proprietary Solutions and consumables designed to eliminate airborne and surface odors. Our products are completely safe to use and environmentally friendly – formulated with natural organic compounds and essential oils.

AirSolution™ is tested to the highest health & safety standard with current toxicology studies (eye, oral, inhalation and dermal irritation/corrosion).



### Selected products for the commercial waste industry



#### *Odor Neutralizers and Reactants*

*Engineered odor control solutions for atomizing/fogging/misting applications.*

PRODUCT NAME	URINE	SWEAT	MUSTY	GARBAGE	WET FOOD	SOLVENTS	FOOD PROCESSING	TOBACCO SMOKE
#9005 - Forest Clean				X	X			
#9015 - Fresh & Clean				X	X	X	X	A
#9023 - Southern Breeze				X				
#9441 - Apple	A	A	A	X	A		A	
#9442 - Fresh	A	A	A	X	A		A	
#9007 - Baby Fresh	X	X	X					
#9010 - Florida Breeze	X	X	X					
#9028 - Spring Garden	X	X	X					
#9030 - No Scent				X	X	X	X	A
#9037 - Smoke Away								X

- over 80 different AirSolution formulations are available. Please contact your local representative for assistance with selecting the appropriate formulation(s) for your application.

Garbage
  People
 X= Effective
A=Applicable



SURFACE DETAIL  
BEFORE



SURFACE DETAIL  
AFTER

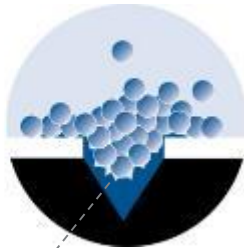

ACCUMULATED  
DECOMPOSING  
MATER

### BioStreme™

The **BioStreme™ formulations** have been specifically developed to enhance growth and reproduction of beneficial indigenous bacteria through engineered formulations of optimized essential nutrients. The proprietary formula consists of micronutrients, amino acids and complex organic extracts: the building blocks for growth and synthesis of new cell material. With the use of BioStreme™, effective management of virtually any biological treatment process can be achieved and/or enhanced to provide increased treatment efficiency and operational cost savings.



# OUR HYDRAULIC MISTING SYSTEMS

Innovative Engineering



The AirStreme product line is a complete offering of technologically advanced automated misting equipment and solutions.

Professional quality design and precision controls make AirStreme systems and solutions the preferred choice for such applications as odor control, pest control, environmental cooling and dust suppression.

**AHP**  
Atomizing High  
Pressure System



**AMS**  
Atomizing Misting System

# OUR HYDRAULIC MISTING SYSTEMS

Innovative Engineering



**AirStreme™**



**AMT**  
Atomizing Misting  
Tankless



**AMC**  
Atomizing Misting  
Continuous



Tubing & Nozzles



Drums with mixing dilution station

# OUR PNEUMATIC MISTING SYSTEMS

Innovative Engineering

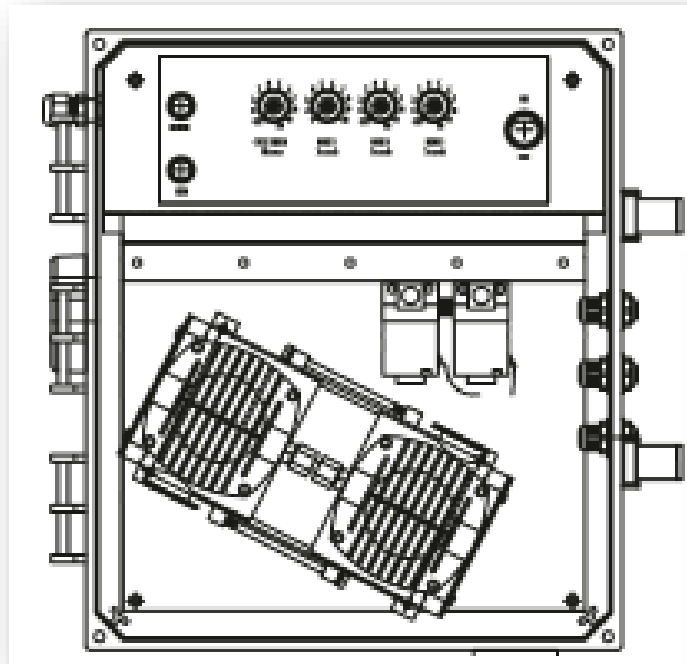

## AirPro™ System

Integrated Controller Design

Adjustable Programming

Individual Zone Application

Weather/Corrosion Resistant

Quiet Operation

Easy to install and quick connect

Professional quality design make **AirStreme™ pneumatic control unit** and **XStreme™ Vapor Systems** the preferred choice for commercial odor control applications.



# OUR PNEUMATIC MISTING SYSTEMS

Innovative Engineering

**Airpro with  
-Vapor Units  
and/or  
-Spray Units:**

Flexibility of Airpro being  
able to connect to various  
water-based spray stations  
(SU-2, SU-4, SU-20)

And/Or

to connect to oil-based  
vapor stations (VAP500,  
VAP1000)



# OUR PNEUMATIC MISTING SYSTEMS

Innovative Engineering



## AirPro with Vapor Units and/or Spray Units:

AirPro can be connected  
to up to **6** XStreme™  
Vapor Units.

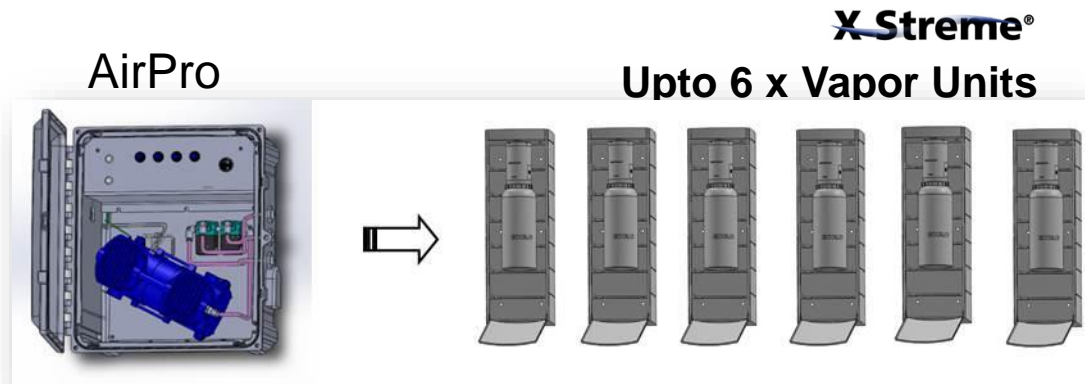

AirPro can be connected  
to up to **3** Satellite Units.

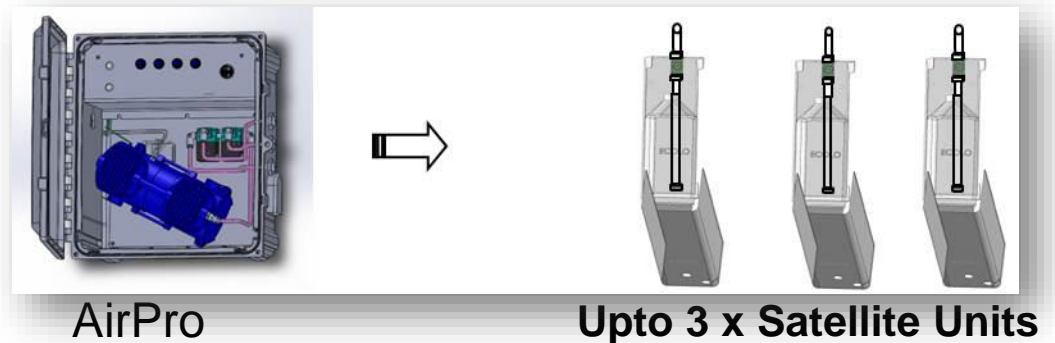

# OUR VAPOR SYSTEM

Innovative Engineering

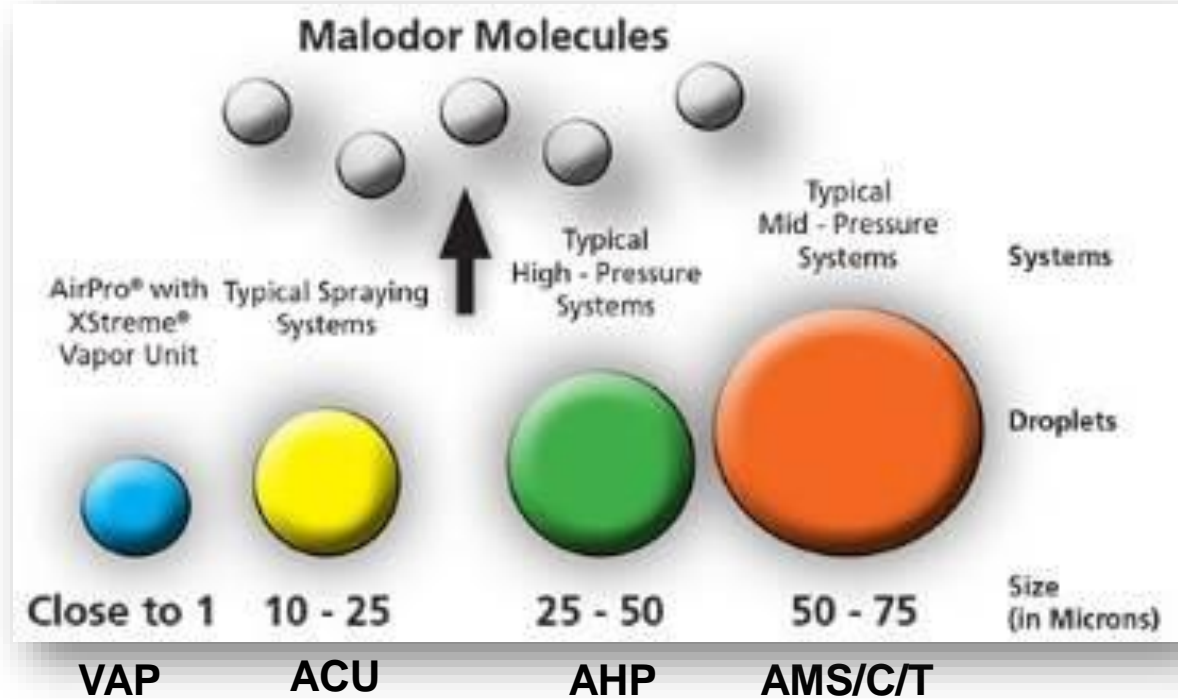
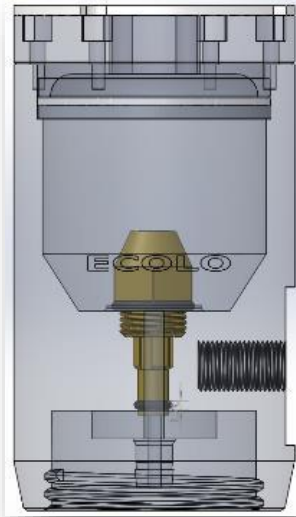

**XStreme™ Vapor Systems** have been finely machined to provide consistent output of ultra fine particles that consistently average 1 micron. These smaller, lighter and higher numbers of particles increase the opportunity for collision and absorption between an **XStreme™ Vapor Solution** molecule and an odor molecule.

# OUR VAPOR SYSTEM

Innovative Solutions



*4x1 Litre Refill Case*



**XStreme™ Vapor Solutions** are completely safe to use and environmentally friendly – formulated with natural organic compounds and essential oils common to AirSolution™ line but require no mixing and are highly concentrated.

## Features and Benefits:

- Completely Water-free. No water residual on the floor
- Concentrated and Ready-to-Use – no mixing and reduced shipping costs
- No added VOC or solvent – transports as non-hazardous
- Works with AirPro – operates up to six Vapor Units
- Winter operation – functional in below-freezing temperatures
- Easy installation and service – smaller footprint and less formula required
- Precision machined aluminum vapor head – for reliability and long term use
- True odor neutralizers – not synthetic oils to simply mask odors



# OUR GELTECH RANGE

Innovative Solutions



## GelTech



# OUR MISTING SYSTEMS INSTALLATION

Innovative Engineering

## *Trash Room Installation*

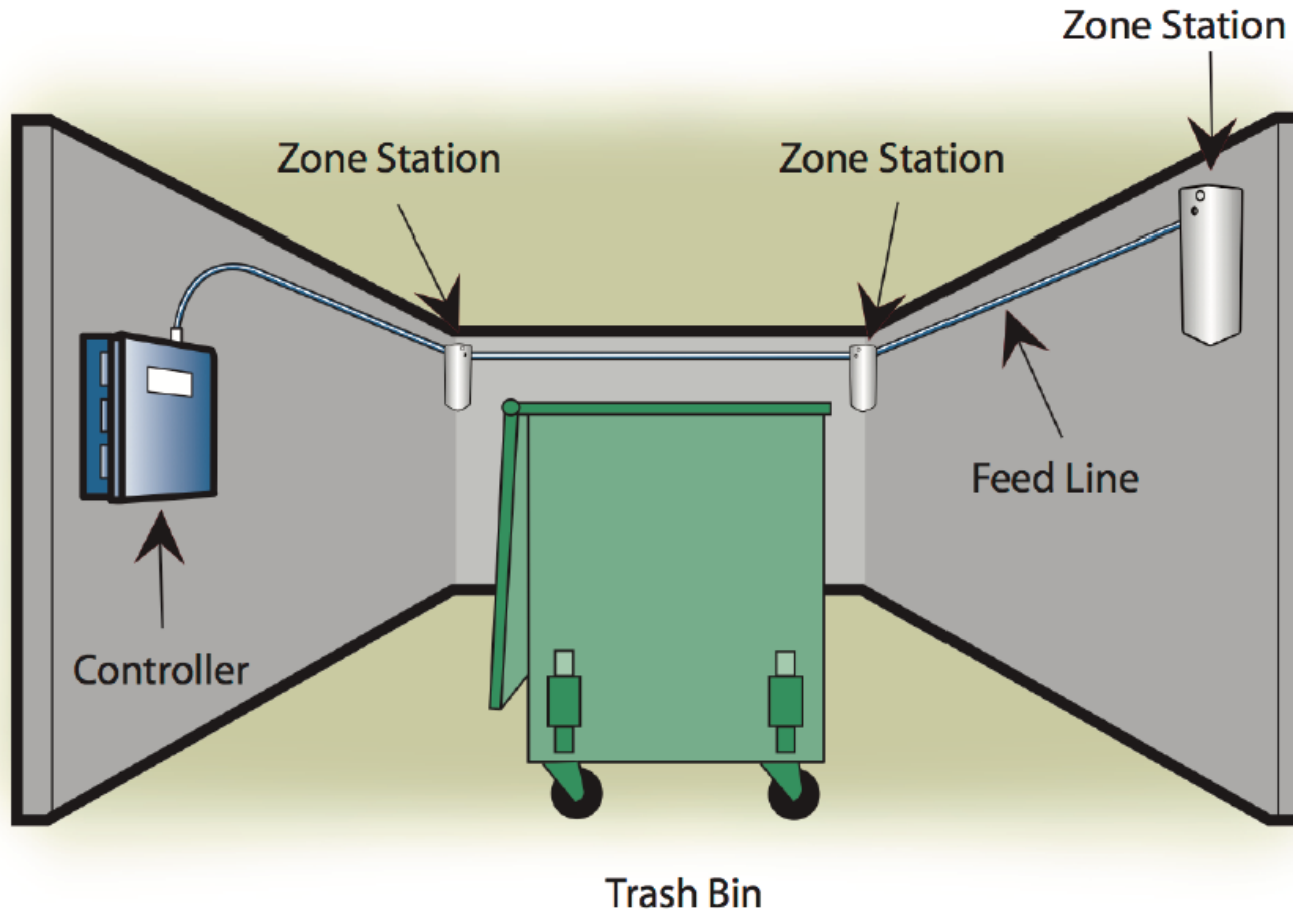

# Sludge Processing and Composting

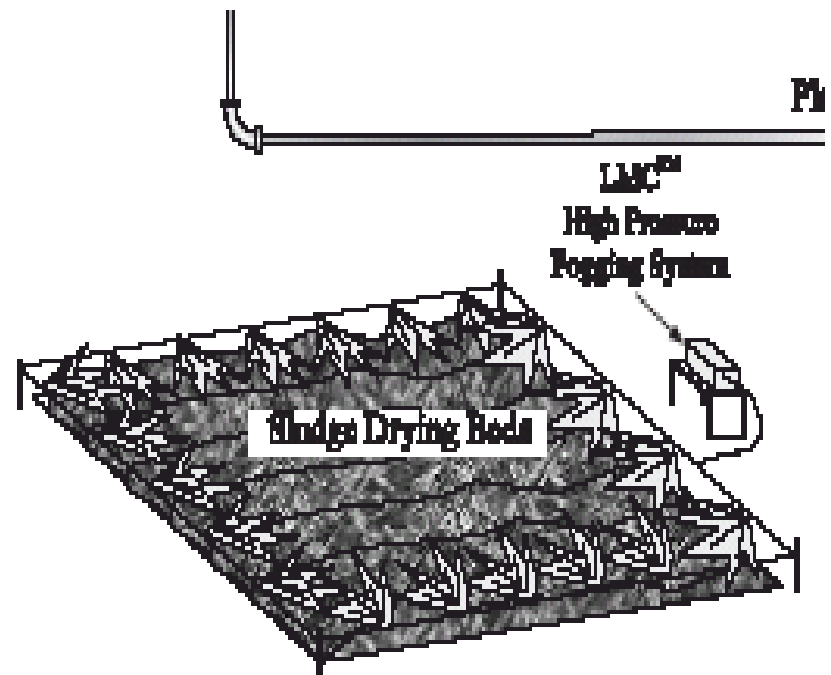
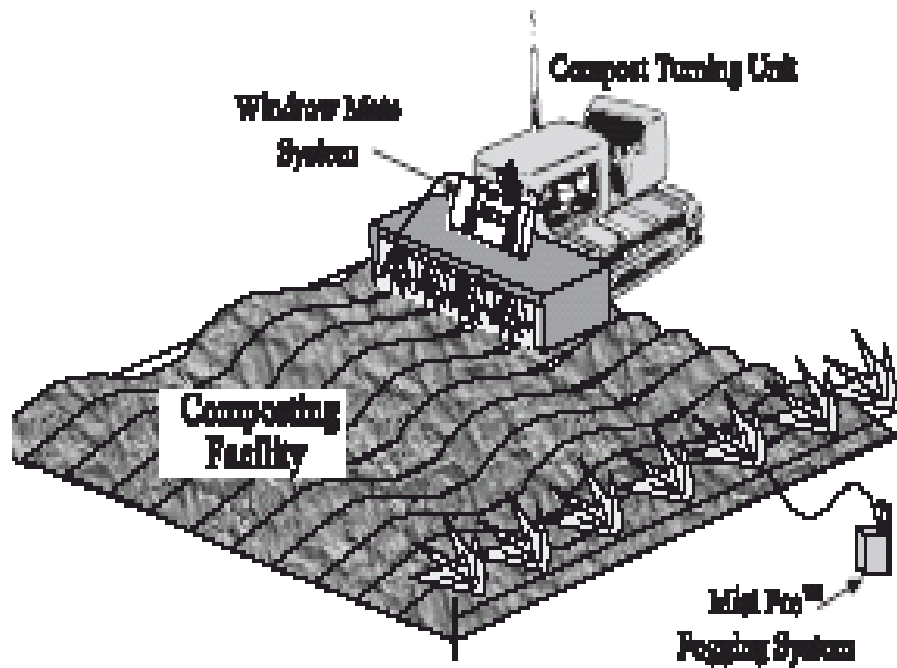

# Wastewater Collection System

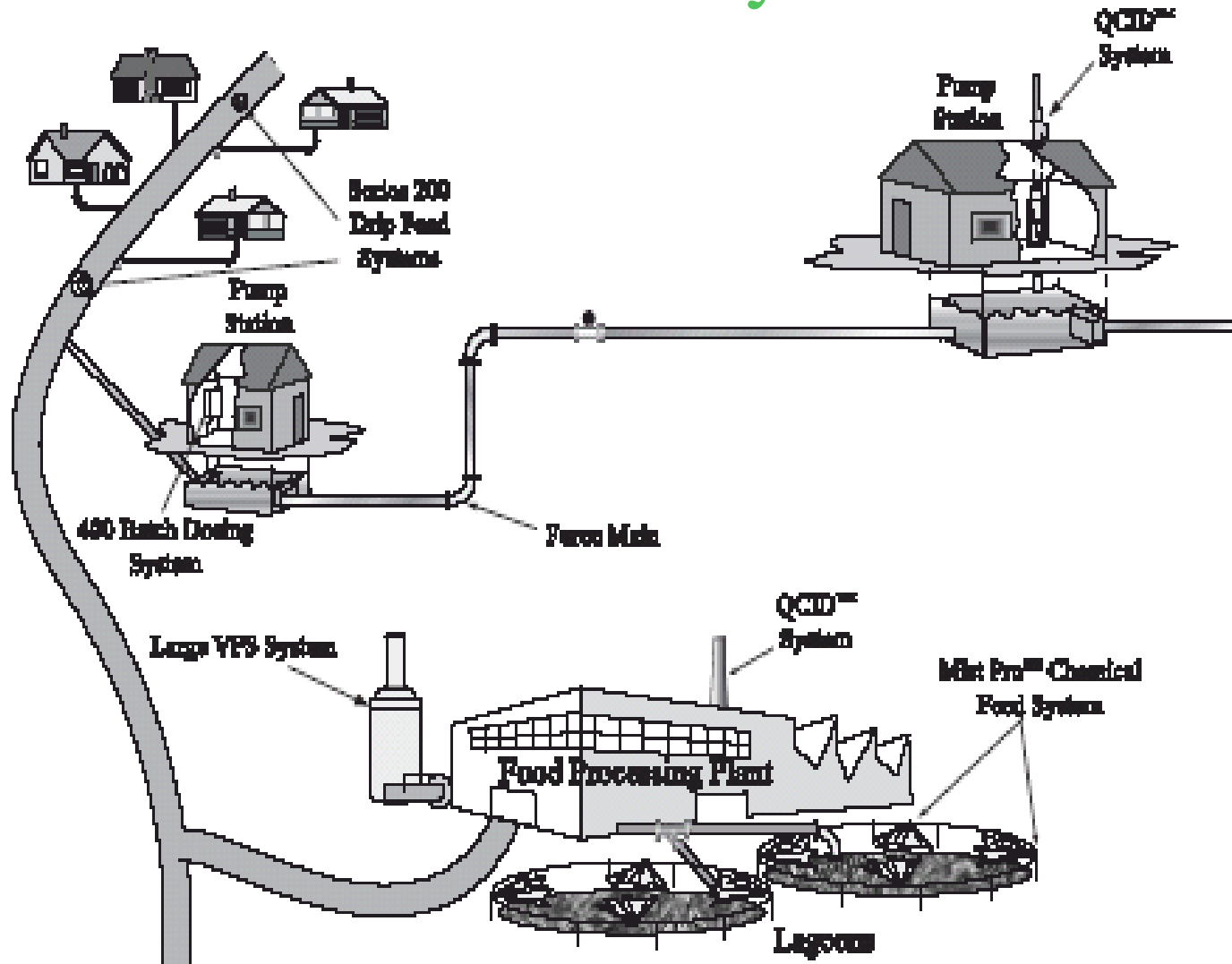



# Wastewater Treatment Plant

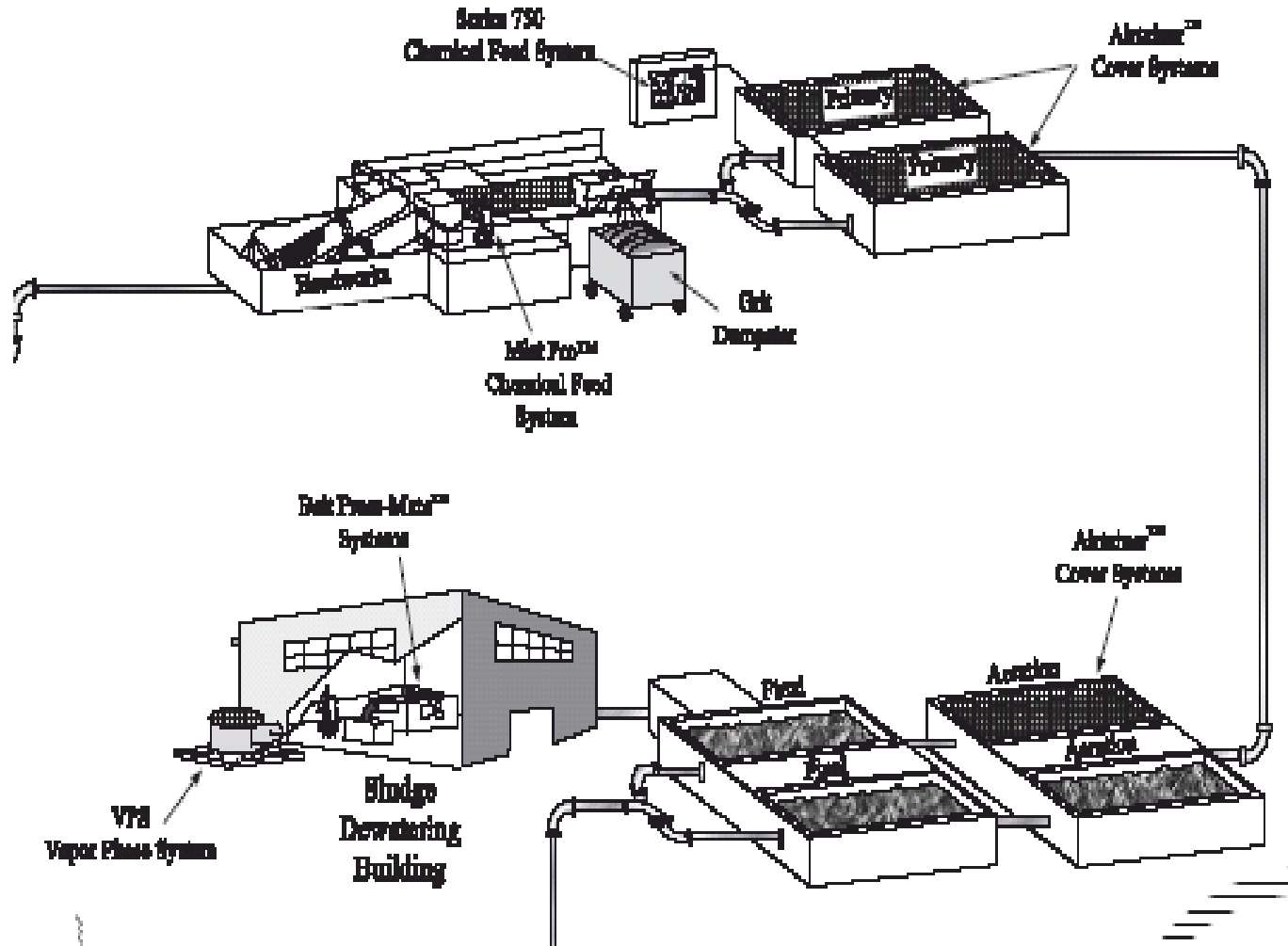

# OUR MISTING SYSTEMS INSTALLATION

Innovative Engineering

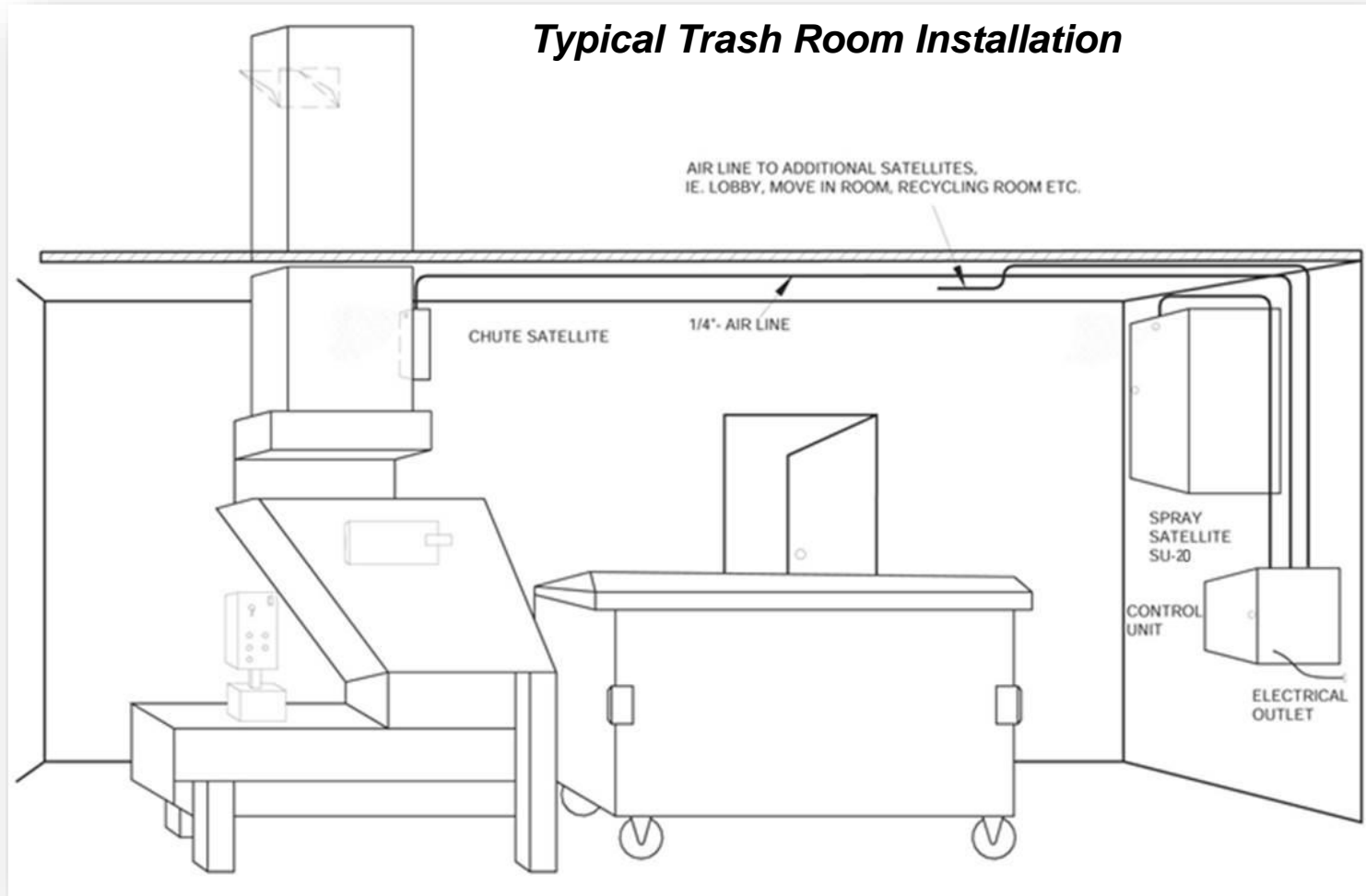

# OUR MISTING SYSTEMS INSTALLATION

Innovative Engineering



*XStreme Vapor Trash Room Installation*

**XStreme®**

# OUR MISTING SYSTEMS INSTALLATION

Innovative Engineering



## Typical Kitchen Exhaust Installation

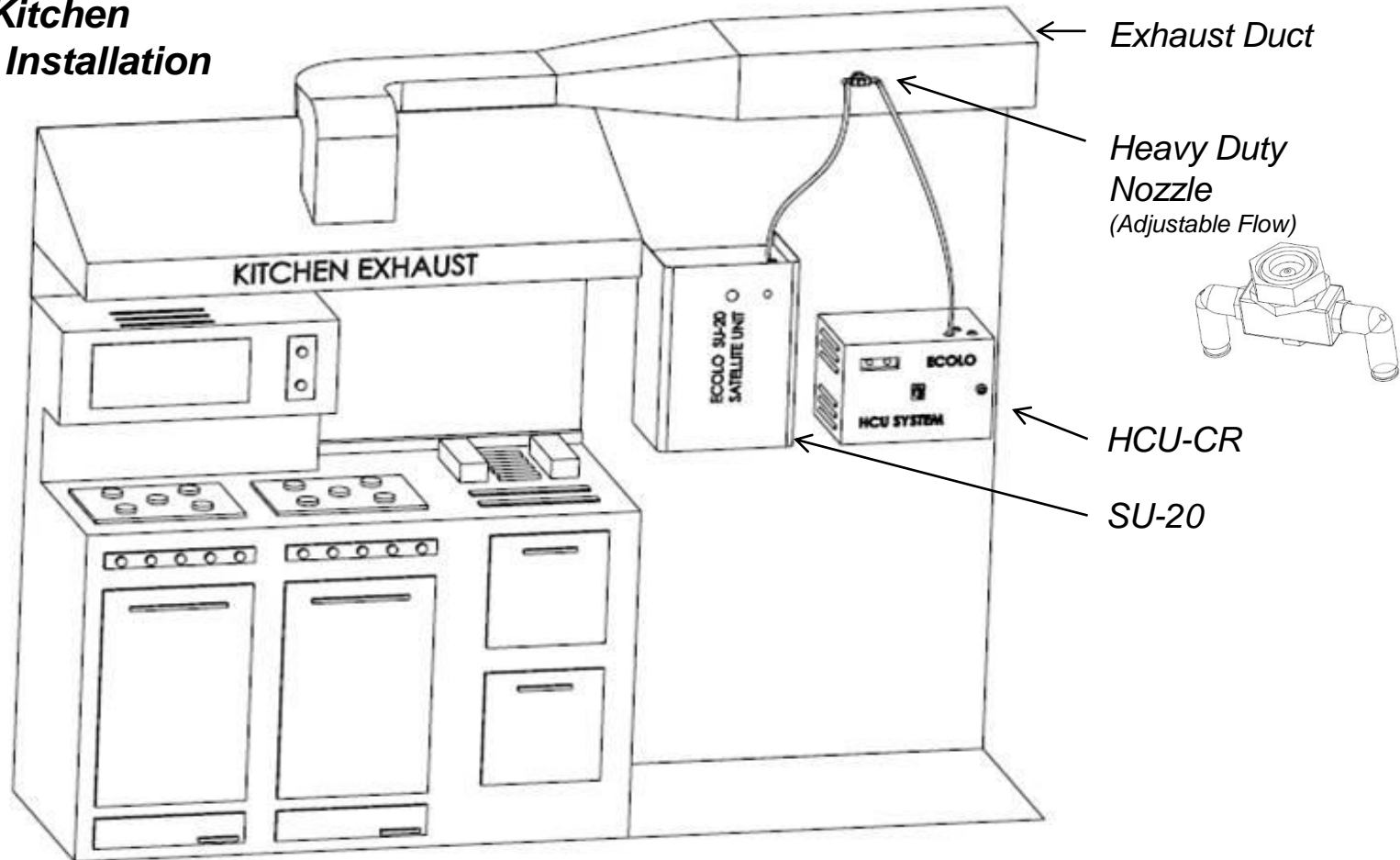

# OUR MISTING SYSTEMS INSTALLATION

Innovative Engineering

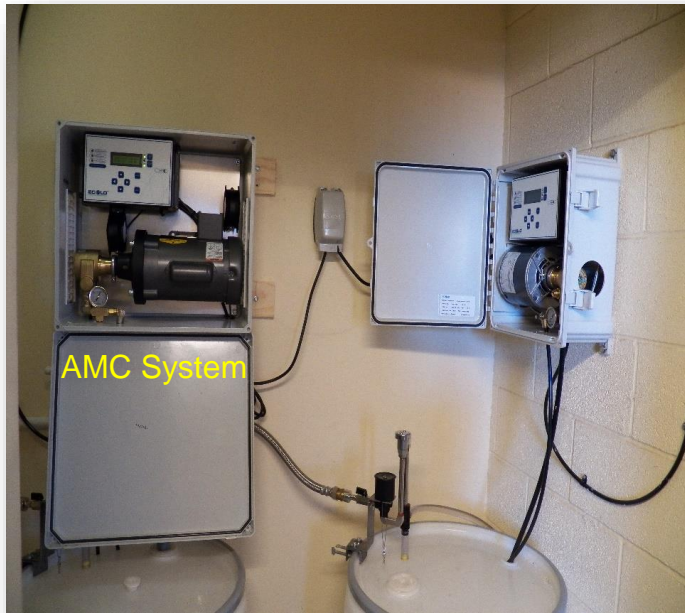



# OUR MISTING SYSTEMS INSTALLATION

Innovative Engineering



## *Misting*



# OUR MISTING SYSTEMS INSTALLATION

Innovative Engineering



## *Misting*

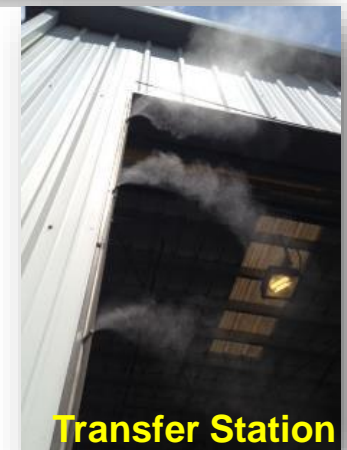



# OUR MISTING SYSTEMS INSTALLATION

Innovative Engineering



**BioStreme™**

## *Foaming Application*



# OUR MISTING SYSTEMS INSTALLATION

Innovative Engineering



# INDUSTRIAL ODOR TREATMENT

Innovative Engineering





# OUR MISTING – HP MOBILE TRAILER SYSTEM

Innovative Engineering



**Self-Contained  
High Pressure  
Trailer**



# OUR MISTING / DUST CONTROL CANNON

Innovative Engineering



# OUR MISTING / DUST CONTROL CANNON

Innovative Engineering





# NEW CONTROLLER

*New Digital PLC Controller  
Has replaced the existing Controller*

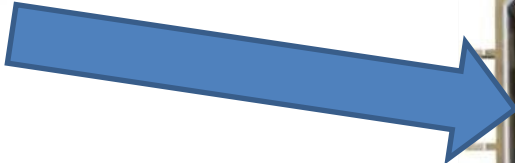
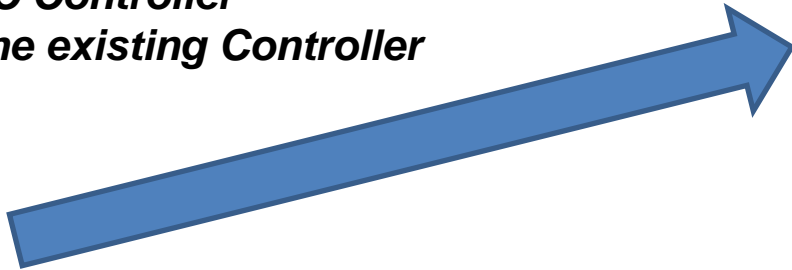

## NEW CONTROLLER

### ***ACU.18, ACU.53, ACU.87***

- ***Continuous Duty***
- ***Fan Cooled***
- ***Digital***





# NEW CONTROLLER

**ACU.25 Analog**  
**110v – CSA Certified**  
**220v – CE Certified**



### The Ecolo Difference

- High pressure, mid pressure and pneumatic misting systems
- Over **60 patented** and proprietary odor control formulations
- Cost-effective and environmentally responsible
- Consolidated product offering over multiple industries
- ISO 9001 Quality Control Certified
- Safe for Preparation and Use - Toxicology Reports Available  
(eye, oral, inhalation and dermal irritation/corrosion)



# YOUR PARTNER IN ODOR CONTROL



## SOME OF OUR CUSTOMERS

Some of our most recognizable customer brands continue to acknowledge our highest standard of product quality and service in odor control industry.



**Tyson Foods, Inc.**



**Thank You**

**Questions?**

Hassan Hayek  
Ecolo, Toronto, Canada  
Cell +1 (647) 331 0847  
[hassan@ecolo.com](mailto:hassan@ecolo.com)